

A WORLD CLASS MANUFACTURING FACILITY



ELEMENT26
ENGINEERING DWC-LLC

Element 26 Engineering DWC endeavor to become a key contributor to the advancement of local and regional development in aviation, automotive, aerospace, and oil and gas industries.



Member of
مجموعة شركات حسني
HASSANI GROUP OF COMPANIES

Since 1912

Group Profile

Hassani Group's first commercial activity in the UAE Commenced in 1912 when Mr. Baba Hassan Hassani founded a small convenience store to supply basic amenities to a scarcely populated Dubai.

Hassani Group of Companies is a UAE family owned conglomerate established over 100 years ago with diversified activities employing over 6000 people across three continents.



مجموعة شركات حسني
HASSANI GROUP OF COMPANIES

Since 1912





Hassani Activities

Retail & Services



Transportation of non hazardous solid waste



General land transportation



Al Quoz Cold Store

Cold store rental -30 to +25°



Professional fishing equipment



Energy saving equipments, CCTV & solar system



Elevators & electronic instrumentation solution



Fashion products & accessories



Beauty & spa centre



Primavera Dry Cleaning

Commercial dry cleaning

Real Estate & Contracting



Technoman contracting is the construction arm of the group which oversees construction of all Hassani group developments with unlimited capabilities



Hassani Real Estate

Hassani Real Estate currently consists of over 7,000 apartments, 167 shops, 102 villas, 115 warehouses, 3 hotels, 2 shopping malls, 1 hospital & 6 labor camps

Trading & Distribution



Proud distribution of number of international & local FMCG products



One stop sales centre for all types of packaging covering all industries



Distributor of high quality building materials specifically for the joinery industry



Hassani Activities

Food Manufacturing



Crown Food Industry

Specialized in liquid and semi solid food products such as tomato paste, ketchup, hot sauce, vinegar, jam, honey & dressings.



Hassani Baby Food & Milk Powder Production Factory

First milk powder and baby cereal production & packaging in the UAE



Hassani Food Industries

Specialised in powder & granule food products in vast range of packaging and sizes producing over one hundred SKUs



Crown Dairy Industry

Manufacturer of long life sterilized as well as fresh dairy products in variety of packaging such as metal cans, tetra pack, gable top and plastic containers



مصنع كراون لمنتجات الطعام
CROWN EDIBLE OIL FACTORY LLC

Edible oil refinery and filling in all types packaging



مصنع كراون للخضار
CROWN VEGETABLE FACTORY LLC

Production of canned vegetables in various packaging



Takamoul Afrique Senegal

Situated in senegal TKS processes fresh tomato right from the fields for production of tomato paste and sauces.



Pastalini Food Processing LLC

Pastalini is a fully automated pasta, noodles & snack pellets manufacturing.



Situated in the UK is the pioneer producer of all the bakery powder products



Largest single fish processing and cannery and the only fish canning factory in oman-salalah



Processing of all types of seafood for supermarkets hotels & catering

Industrial Manufacturing



Designs & Manufacturing of metal cans and closures for fancy cans, general Line can & sterilized food cans



Designs and production of duplex board and all types of labels. using wide web, narrow web & offset technology



Design & Production of all types of corrugated box, trays and boards



Manufacturing all types of plastic products using injection blow and compaction molding for PE and PET materials



Manufacturer of special purpose machinery and tools for wide range of industries such as plastic, food, logistics, water treatment industries



One of the largest factory in the UAE specialized in commercial furniture such as panels, doors and knockdown furniture



Design and manufacturing of all kinds of cloths specializing on embroidered products



Bespoke joinery projects and shop fitouts



Specialized in manufacturing of airport ground support equipment, machined parts and fabrication etc.

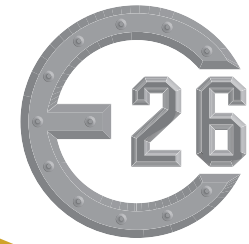

Overview

Element 26 Engineering DWC-LLC was incorporated in 2019. The company manufactures material handling, loading, and lifting equipment, machines parts and fabrication for aviation and aerospace, oil and gas, and defense industries.

A dedicated manufacturer of Airport Ground Support equipment (GSE) in the Middle East, Element 26 Engineering DWC can produce airport diesel and electric tow tractors and aircraft pushback in addition to a range of other GSE equipment that is either being developed in house or in collaboration with established manufacturers.

Our current airport GSE Production capability includes:

1. 2.0T DBP diesel tractor
2. 2.5T DBP diesel and electric tractors
3. 3.5T DBP diesel and electric cargo and pushback tractors
4. 5.0T DBP diesel and electric cargo and pushback tractors
5. 120KN diesel pushback tractor
6. A complete range of non-motorized GSE including dollies, passenger, and maintenance steps.

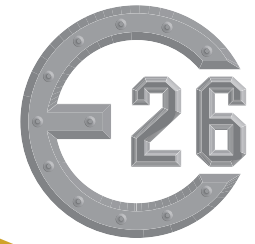

Machine Capabilities

The factory range of equipment and machinery includes:

1. CNC cutting and bending (laser, waterjet, and oxy-acetylene plasma)
2. Three, Four, and Five-axis CNC machining centers (milling, turning, mutli-tasking)
3. Robotic bending and welding
4. Two sets of large volume painting and paint drying booths.
5. 52 meter semi automated assembly lines
6. CMM and ROMER Absolute Arm with integrated scanner R S3



Business Activities

Element 26 Engineering DWC has three core activities;

1. Complete production and after sales of GES equipment.
2. Machines part mass production.
3. Steel and metal fabrication services.



120KN Pushback Tractor



AZM 25/20 Ton Tow Tractor



High Precision Machined Parts



Military Cab Trolleys



Sand Car (1000 hp)

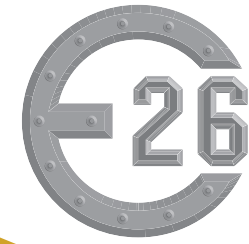

GSE Manufacturing

Under the GSE category our product range includes:

- Diesel tow tractors (8000-2000 DBP)
- Electric tow tractors (8000-2000 DBP)
- 120KN aircraft pushback tractor
- A range of airport luggage and cargo dollies
- Aircraft catering trucks and medical - high lifts (up to 5800 mm heights)
- Airport ground maintenance equipment

Our range of tractors can be customized to meet customers needs. Special options can be provided based on customer needs.

We offer 24 months warranty on our products and contract packages for services, maintenance and spare parts.



120KN Pushback Tractor



AZM 2.0/2.5T DBP Diesel Tractor



AZM E2.5T DBP Electric Tractor



Baggage Dolly



AZM 2.0/2.5T Tow Tractor (sample specifications)



ENGINE SPECIFICATION	AZM D50	AZM D55
DBP Rating	2000 kg	2500kg
Manufacturer	Cummins	Cummins
Model	B3.3	B3.3 T
Number of Cylinders	4	4
Rated HP (2600 RPM)	48 KW	55 KW
Rated Torque (1600 RPM)	214 N-m	245 N-m

PHYSICAL DATA (2.5T)		
Weight		
Total Weight		3200 kg
Weight Distribution	Front	1200 kg
	Rear	2000 kg
Dimension		
Overall Length	W/o Tow Hitch	2677 mm
	W/ Tow Hitch	2904 mm
Overall Width (A)		1416 mm
Height (C)		1354 mm
Drawbar Height		344 mm
Wheel Base		1705 mm

Ground Clearance		150 mm
Inside Turning Radius (B)		2439 mm
Tire Size	Front	650X10
	Rear	205R16C
Wheel Track	Front	1186 mm
	Rear	1225 mm
Performance		
Travel Speed (MAX)		25 kph
Towed Weight		20-25 tons
Drawbar Pull Range (kg)		2000-2500
Gradeability		%8

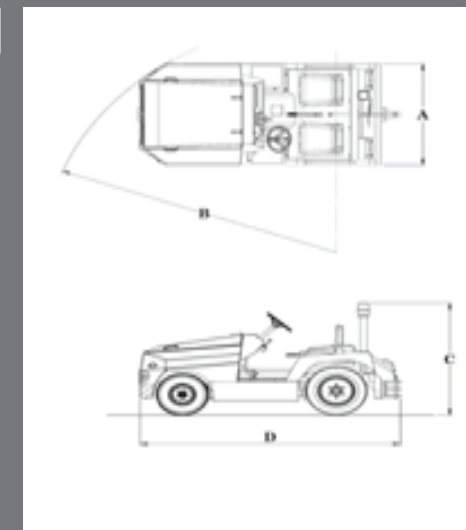



AZM E 2.5T Tow Tractor (sample specifications)



Weight z		
Total Weight		3455 kg
Weight Distribution	Front	1797 kg
	Rear	1658 kg
Dimension		
Overall Length	W/out Tow Hitch (L)	3099 mm
	W/ Tow Hitch (A)	3301 mm
Overall Width (W)		1384 mm
Height (H)		1183 mm
Drawbar Height		345 mm
Wheelbase (WB)		1750 mm
Ground Clearance		140 mm
Turning Radius		2550 mm
Tire Size	Front	6.50 x 10
	Rear	205/R 16 C
Wheel Track	Front (FT)	1174 mm
	Rear (RT)	1144 mm
Over Hang	Front (FT)	894 mm
	Rear (RT)	455 mm

Performance		
Travel Speed	Laden	16 km/hr
	Unladen	25 km/hr
Towed Weight		25 Tons
Maximum Drawbar Pull		2500 kg
Gradeability		%5
Drive	Option	
Type	Single Integrated Axle	Dual Drive
HP@RPM	20 KW @ 2200	12 KW @ 1900 RPM ea
Torque @ RPM	332 N-m @ 500A/850 RPM	
Battery		
Voltage	/Accessory	12 V
	/System	80 V
Brake System		
Brake Type	Front	Disc
	Rear	
Parking		Mechanical
Steering System		
Steering Type		Hydrostatic

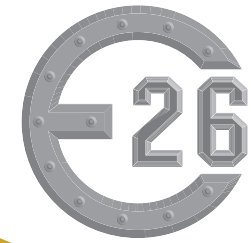

AZM -120 KN Push Back Tractor (sample specifications)

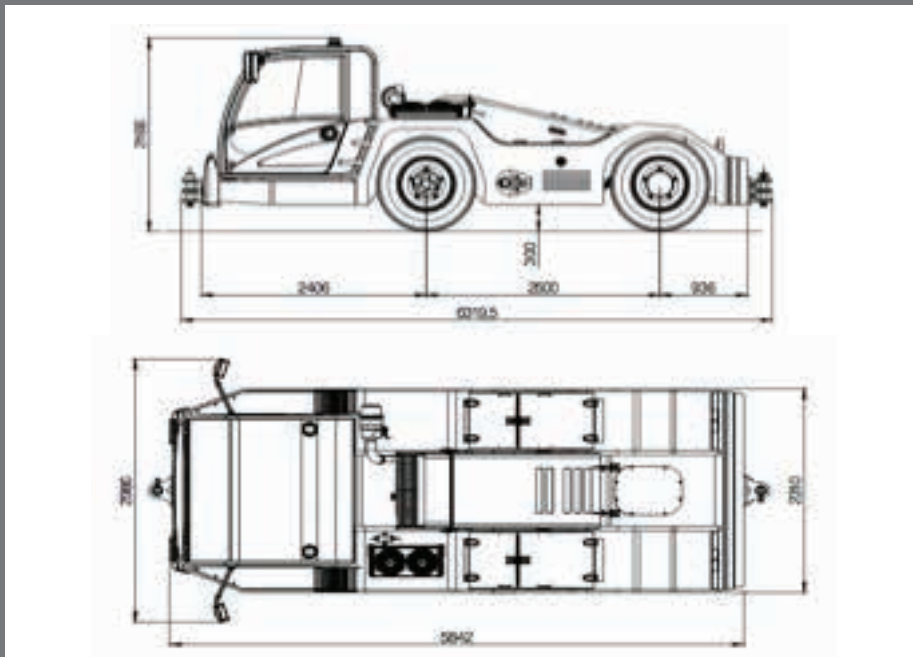

PHYSICAL DATA	
Operating Weight	1600 kg
Towed Weight	180 Tons (Dry Tarmac)
Maximum DBP	120 KN
Engine Power	85 KW @2200 RPM Turbo- Charged
Transmission	4 Speed Forward, 4 Speed Reverse (Power Shift)
Front Axle	Steer/Drive - Pin Mounted
Rear Axle	Steer/Drive
Voltage	12 Volts
Brake System	Wet Type - 3 Plate Controlled/Retract
Steering	Hydrostatic - 2 Cylinder, Front & Back

DIMENSION		
Overall Length	W/out Tow Hitch	5842 mm
	W/ Tow Hitch	6320 mm
Width		2310 mm
Height (W/ Cabinet and Beacon)		2166 mm
Drawbar Height		350 mm
Floor Clearance		300 mm
Tire Size		295/80R22.5
Turning Radius		4960 mm

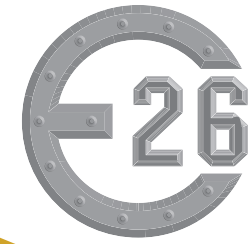

2- GSE Refurbishment Services

The GSE industry has a growing need for refurbishment services of aging GSE equipment. This measure allows ground handling companies to cut operating cost. Element 26 Engineering DWC offers GSE refurbishment services for local and regional airport ground handling companies for all types of equipment including container loaders, pushbacks, A/C units, and belt loaders





Machined Parts and Specialty Metal Fabrication



Element 26 Engineering DWC offers metal fabrication services for complete assemblies and sub-assemblies to support special purpose vehicle industries in the UAE.

Our metal fabrication and machined parts product range covers manufacturing of refrigerated trucks (4.5 meter chassis and cab from Hino/Isuzu), 7-ton portable loading ramps, 3-ton jib cranes, military vehicle assemblies and subassemblies, special grade aluminum fuel tanks, and several types of trollies used in automotive and aviation industries.





Partners

Undagrid (www.undagrid.com)

Provides GSE Tracker solution for optimizing the complete flow process on the airport

S-P-S (www.s-p-s.aero)

Is one of the largest airport service providers around the globe, designing, manufacturing and delivering ground support equipment such as Baggage Carts, 5ft Dollies, 10ft Dollies, 20ft Dollies, Stairs, Motorized and Cargo Handling Equipment.

Weihai Guangtai Airport Equipment (www.guangtai.com.cn)

A leading developer and manufacturer of Ground Support Equipment in Asia and has 4 business categories: Airport Ground Handling Equipment , Firefighting Equipment , Special Purpose Vehicles and Power and Electron Technology .

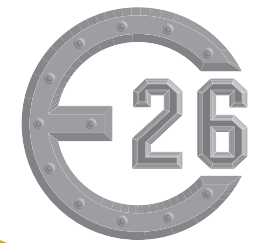

Customers





A WORLD CLASS MANUFACTURING FACILITY

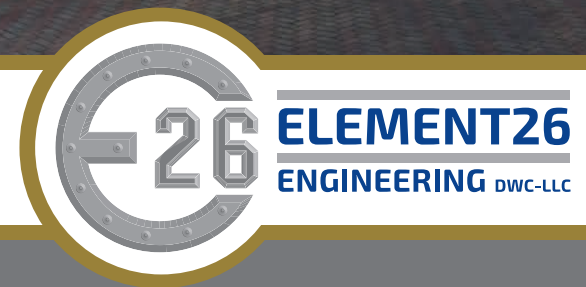

Plot : WC - 08 • Logistics District • Dubai World Central • P.O. Box : 286 • Dubai • United Arab Emirates • Tel. : +971 4 804 8888 • Fax : +971 4 804 8889